

# **Multi Vision™**

## **Multivariable Transmitter**

# 2010TC for Differential Pressure, Pressure and Temperature (Mass Flow)

Spans: 0.5 mbar ... 100 bar

10/15-4.12 EN



2010TCSW.TIF

- Compensated mass flow measurement
- Measured media: gases, vapours, liquids
- Accuracy: 0.075% (option 0.05%)
- One sided overload up to rated pressure; max. 400 bar
- Large turn down ratio 100 : 1
- Span and zero externally adjustable
- In conjunction with the LCD indicator, the transmitter can be configured with the external keys
- Communication protocol:
  - PROFIBUS PA or • Foundation Fieldbus or
  - HART, 4...20mA
- Explosion protection:
  - "Intrinsic Safety" • "Flameproof Enclosure"
  - connection to "Zone 0"
- Surge voltage resistant acc. to IEC 61000-4
- Interchangeable electronics with self reconfiguration

### **1 Application**

The transmitter 2010TC of the **Multi Vision** - series is a mass flow measuring device with an analogue or digital output signal for the process industry. The transmitter 2010TC measures accurately and simultaneously the differential pressure, the static pressure and with a RTD in four-wire technique the process temperature of aggressive and non-aggressive media. The electronics calculate the compensated mass flow using these dynamic fluid conditions.

The measuring ranges are from 10 mbar to 100 bar (1 kPa to 10 MPa), each for the nominal pressure ranges 20, 100 and 400 bar.

# **ABB**

## Technical data

### 2 Principle of Operation and Construction

The transmitter has a modular design and consists of the differential pressure sensor module with an integrated electronic matching unit, an amplifier with control unit as well as an input for a RTD in four-wire technique for process temperature.

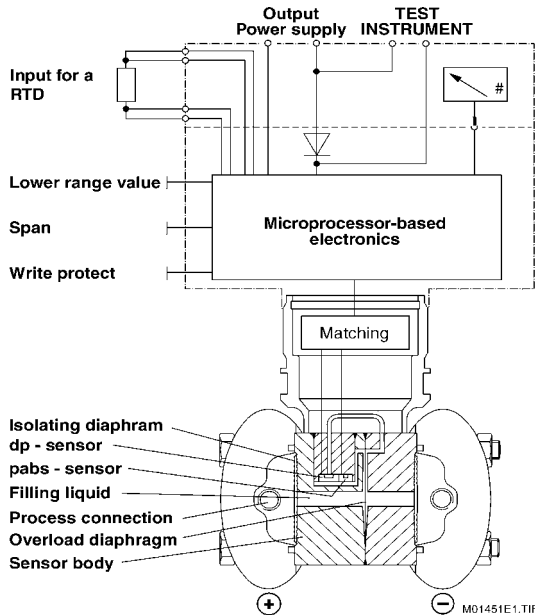

Transmitter 2010TC

The completely welded sensor module is a twin-chamber system with an integral overload diaphragm, an internal absolute pressure sensor and a silicon differential pressure sensor. The absolute pressure sensor, which is only exposed to the pressure at the high pressure side (⊕), acts as a reference value to compensate for the static pressure. The differential pressure sensor is connected via a capillary tube to the negative side of the sensor module. The applied differential pressure (dp) is transferred via the separating diaphragm and the fill fluid to the diaphragms of the silicon differential pressure sensor.

A minimal deflection of the silicon diaphragm changes the output voltage of the pick-up system. This pressure proportional output voltage is digitalized by matching electronics and fed to the amplifier. The amplifier linearizes and temperature compensates this signal before it together with the values for dp, p and T is converted into a compensated mass flow proportional signal. Apart from the mass flow (qm) the values dp, p, T and qv are also available for further use.

### 3 Input

#### Measured value

Differential pressure, static pressure (absolute pressure) and process temperature

#### Upper and lower range values - dp-sensor

**Lower range value** (continuously adjustable)

-100% to +100% of the URL

**Upper range value** (continuously adjustable)

Up to 100% of the URL

#### Spans

**dp-sensor:** The adjusted span must not be lower than the minimum span (recommendation for square root function: at least 10% of the range).

Measuring ranges

Code	min.	max.	SWP
A	50 Pa / 0.5 mbar	1 kPa / 10 mbar	6
B	200 Pa / 2 mbar	6 kPa / 60 mbar	20 / 100 / 400

C	400 Pa / 4 mbar	40 kPa / 400 mbar	20 / 100 / 400
D	2.5 kPa / 25 mbar	250 kPa / 2.5 bar	20 / 100 / 400
E	20 kPa / 0.2 bar	2 MPa / 20 bar	20 / 100 / 400
G	100 kPa / 1 bar	10 MPa / 100 bar	20 / 100 / 400

**pabs sensor:** The adjusted span must not be lower than the minimum span

Measuring ranges

Code	min.	max.
2	4 MPa / 40 bar	40 MPa / 400 bar
3	1 MPa / 10 bar	10 MPa / 100 bar
4	200 kPa / 2 bar	2 MPa / 20 bar

### Process temperature

External RTD in four-wire technique

RTD: -50 °C ... +650 °C

### 4 Output

#### Output signal

##### Transmitters with 4...20mA

Analogue signal 4 ... 20 mA

Output signal limits: I<sub>min</sub> = 3.5 mA, I<sub>max</sub> = 22.5 mA (configurable).

Standard setting: I<sub>min</sub> = 3.8 mA, I<sub>max</sub> = 20.5 mA

#### Alarm current

Min. alarm current: configurable from 3.5 mA to 4 mA, standard setting: 3.6 mA

Max. alarm current: configurable from 20 mA to 22.5 mA, standard setting: 21 mA

Standard setting: max. alarm current

#### Load

##### Transmitters with 4...20 mA

$$R \leq \frac{U_s - 10,5V}{I_{max}} \text{ in kOhm}$$

I<sub>max</sub> = 20 ... 22.5 mA (configurable)

U<sub>s</sub> = supply voltage

min. power supply: 10.5 VDC, 14 VDC with backlit LCD-indicator

min. load for digital communications > 250 Ohm

#### Field Bus units (communication code: P / F)

Digital signal

Transmission technique: acc. IEC 61158-2

Power supply: 9 VDC ... 36 V DC

Base current: 10 mA

Transmission rate: 31.25 kbits/s

PROFIBUS-PA: Version 3.0, Profile B for pressure transmitters; Ident No.: 04C2 HEX

Foundation Fieldbus: FF-890 / 891 and FF-902 / 903

#### Characteristic

Mass flow calculation, compensating all pressure (p) and temperature (T) effects completely.

Calculation is performed as per the formula:

$$q_m = k \times \frac{C \times \epsilon}{\sqrt{1 - \beta^4}} \times d^2 \times \sqrt{\Delta p \times \rho}$$

### 5 Accuracy

#### Reference conditions

to DIN IEC 770

Temperature: 20 °C

Relative humidity: 65 %

Atmospheric pressure: 1013mbar (1013 hPa)

additional conditions:

Separating diaphragm material "Hastelloy C" <sup>1)</sup>, fill fluid "silicone oil"

All specifications are limits and relate to the output range or calibrated range. The influences marked \* relate to the measuring range (URL) and are to be multiplied by the turn down factor. The turn down factor should be kept to a minimum.

## Technical data

### Conformity

dp-sensor:  
0.075 % <sup>2)</sup>  
terminal based, including hysteresis and the dead band (optional  
0.05 %)  
pabs-sensor:  
0.1 %  
Process temperature measurement (RTD):  
+/- 0.3 °C

### Reproducibility

0.01 %

### Hysteresis

0.05 %

### Warm-up time

< 15 s

### Rise time

dependent on the range and the  
turn down ratio  
• range 10 mbar 0.1s ... 1.6s  
additional adjustable time constant 2s  
0...60s

*The effect appearing at the output for square rooting function depends on the function and is to be calculated accordingly.*

### Long-term drift

0.05% per 12 months

### Effect of position

Ranges ≤ 10 mbar  
\* on zero approx. 3.5 mbar x sin ∠°  
(∠° = angular deviation in  
degrees from the nominal  
mounting position)

### Ambient temperature effect (dp- and pabs-sensor)

Thermal change (-40°C ... +80°C) <sup>3)4)</sup>  
\* on zero 0.1 %  
on span  
dp-sensor 0.1 %  
pabs-sensor 0.1 %  
Temperature coefficient (-40°C ... +80°C) <sup>3)4)</sup>  
\* on zero 0.04 % per 10K  
on span  
dp-sensor 0.04 % per 10K  
pabs-sensor 0.04 % per 10K

### Static pressure effect

Range 10 mbar  
on zero 0.05 % per 1 bar  
on span 0.05 % per 1 bar  
Ranges ≥ 60 mbar  
\* on zero 0.05 % per 100 bar  
on span 0.05 % per 100 bar

1) with Tantalum, Monel or Gold Plated Isolating Diaphragm, the factor 1.5 is to be taken into account with static pressure and ambient temperature effect with conformity

2) additionally with turn-down factor > 1:10

$$\pm(0.005 \times \frac{\text{measuring range}}{\text{adjusted span}} - 0.05)\%$$

3) with range 10mbar: -20 °C ... +60 °C

4) with carbon fluoride filling liquid: -20 °C ... +80 °C

## 6 General conditions

### 6.1 Installation conditions

#### Notes on installation

Installation position: The transmitter can be directly flanged in any position. Preferably in such a position that the process flange axes are vertical (horizontal with barrel-type amplifier housing). Deviations from this can cause a shift in the zero, which can be corrected. The electronic housing can be rotated through 360° and can be fixed in any position. A stop prevents the housing being turned too far.

### 6.2 Ambient conditions

#### Ambient temperature

-40 °C ... +85 °C  
Observe approvals for explosion-protected transmitters.

#### Storage temperature / transport temperature

-50 °C ... +85 °C, with LCD-indicator -40 °C ... +85 °C

#### Humidity

Relative humidity: ≤ 95% annual average  
Condensation, icing: admissible

#### Protection class

IP 67

#### Paintwork

epoxy resin, greywhite, RAL 9002

#### Shock resistant

Acceleration: 50g  
Duration: 11ms

#### Vibration resistance

2g up to 1000 Hz

#### Electromagnetic compatibility (EMC)

acc. to IEC 61000-4-2 ... 5  
Definition: Class 3  
Frequency range (IEC 61000-4-3): 20 to 1000 MHz  
Radio suppression (EN 55 011): Limit class B  
Fulfills NAMUR recommendation.

### 6.3 Process conditions

#### Temperature limits

-50 °C ... + 120 °C, at process connection  
+400 °C in conjunction with remote seals.  
O-rings Viton (FPM) -40 °C ... +85 °C

#### Pressure limits

Static pressure limits: from 3.5 kPa abs. (35 mbar abs.) to the nominal pressure  
Proof pressure up to 1.5-times the nominal pressure simultaneously on both sides of the transmitter admissible.

#### Overload limit

One-sided overload up to the rated pressure.

#### Weight

3.5 kg

#### Material

Measuring cell: 316 L stainless steel  
Separating diaphragm(s): Hastelloy / 316 L stainless steel (1.4435) / Tantalum / Monel / gold plated  
Process flange: 316 Ti stainless steel (1.4571)\* / Hastelloy C\* / Monel\* / PVDF  
Nuts and bolts: stainless steel (A4)\*  
Plugs: as process flange material  
Fill fluid: Silicone oil / carbon fluoride  
O-rings: Viton (FPM) / Perbunan (NBR) / PTFE\* / EPDM\*

Amplifier housing /  
Housing cover: aluminium with epoxy resin coat / stainless steel

\* in compliance with NACE MR0175 Class II

#### Process connection

Flange with fixing thread 7/16-20 UNF and 1/4-18 NPT female thread on both sides or flange connection to DIN 19 213 with thread M 10 for 20 bar and 100 bar or M 12 for 400 bar and 1/4-18 NPT female thread on both sides.

## Technical data

### Electrical connections

Two female threads 1/2-14 NPT or M 20 x 1.5 or one plug Han 8 U.  
Screw terminals for wire cross-sections up to 2.5 mm<sup>2</sup>.

### Cable connection compartment / electrical connection

Screw terminals for 0,5...2,5 mm<sup>2</sup>-wires

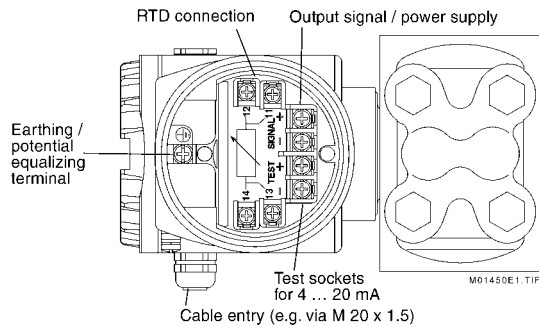

### Electrical connection with plug

Dimensions are in inches (millimeters).

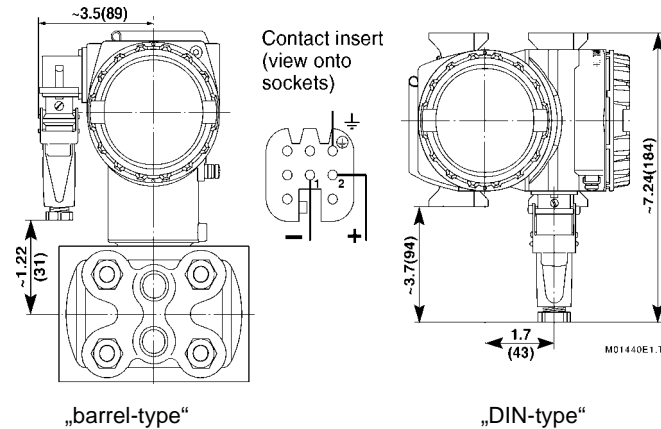

## 7 Display and operation interface

### Operation with keys

Retrofit / optional key unit for external adjustment of zero and span and a write protect switch. There are no physical connections through the housing for the keys.

In conjunction with an LCD indicator, the transmitter can be configured with the keys as follows:

Zero and span with or without applied pressure, oblique sensor, damping, output current during faults, displayed value, pressure unit, linear or square rooting, incl. zero suppression and Lin / Sq. Rt. change over and the temperature unit.

### Operation via remote communications

Communication protocol: PROFIBUS-PA<sup>®</sup> or Foundation Fieldbus<sup>®</sup> or HART<sup>®</sup> or Bailey-FSK for HART<sup>®</sup> and Bailey-FSK:  
Hardware: FSK modem for PC / notebook  
Handheld Terminal: STT 04 or HHT 275

### LCD indicator

2-line, 6-character 19-segment alphanumeric display with additional bar chart display, optionally with back illumination.

User-specific displays:

- mass flow value as a physical unit or percentage of the output current or
- mass flow value and percentage, alternating every 2 seconds or
- output current in mA or
- instrument temperature in freely selectable units or
- free process variable

Diagnostic messages, alarms, measuring range infringements and changes in the configuration are also displayed.

## 8 Power supply

### Transmitters with 4...20mA (communication code: H / S)

Power supply: 10.5 ... 45 VDC (14 ... 45 VDC with backlit indicator), inverse polarity protection, explosion-protected transmitters, observe the approvals.

Harmonic distortion: Maximal permissible voltage ripple of the power supply during the communication:

- 7 V<sub>pp</sub> at 50Hz ≤ f ≤ 100Hz
- 1 V<sub>pp</sub> at 100Hz < f ≤ 200Hz
- 0.2 V<sub>pp</sub> at 200Hz < f ≤ 300Hz

### Field Bus units (communication code: P / F)

Power supply: 9 ... 36 VDC (14 ... 36 VDC with backlit indicator), inverse polarity protection, explosion-protected transmitters, observe the approvals.

## 9 Certificates and Approvals (pending)

Explosion protection, intrinsically safe "i"

Marking (DIN EN 50 014): EEx ia IIC T6

Connection to an intrinsically safe circuit with maximum values:

Temperature class	U <sub>max</sub>	I <sub>max</sub>	P <sub>max</sub>	Ambient temp. maximum
T6	30 V	100 mA	0.5 W	40 °C
T5	30 V	100 mA	0.8 W	40 °C
T4	30 V	100 mA	0.8 W	80 °C
T4	30 V	100 mA	1.0 W	60 °C

Internal capacitance C < 0.01 µF, internal inductance negligible

Explosion protection, flameproof enclosure "d"

Marking (DIN EN 50 014): EEx d IIC T6

Operating conditions: max. ambient temperature 75 °C

### Factory Mutual (FM)

Explosion protection: Class I, Division 1, Groups A, B, C, D  
Class II/III, Division 1, Groups E, F, G

Explosion protected areas:

Indoor or outdoor

Degree of protection:

NEMA Type 4X

### Canadian Standard (CSA)

Explosion protection: Class I, Division 1, Groups A, B, C, D  
Class II, Division 1, Groups E, F, G  
Class III

Explosion protected areas:

Indoor or outdoor

Degree of protection:

NEMA Type 4X

# 2010TC for Differential Pressure, Pressure and Temperature (Mass Flow)

10/15-4.12 EN

**Model ordering number**

**2010TC for Differential Pressure, Pressure and Temperature (Mass Flow)**

		Catalog No.								Code			
<b>Multivariable Transmitter 2010TC for mass flow</b>		<b>V15714-</b>											
<b>Communication</b>													
PROFIBUS-PA			P										
Foundation Fieldbus			F										
HART, 4...20 mA			H										
<b>Measuring Ranges dp</b>													
10 mbar	(1kPa / 5 inch H2O) (max. SWP 6 bar)	adj. to ...		A									
60 mbar	(6kPa / 25 inch H2O)	adj. to ...		B									
400 mbar	(40kPa / 160 inch H2O)	adj. to ...		C									
2.5 bar	(250kPa / 1000 inch H2O)	adj. to ...		D									
20 bar	(2MPa / 300 psi)	adj. to ...		E									
100 bar	(10MPa / 1500 psi)	adj. to ...		G									
<b>Measuring Ranges pabs-sensor</b>													
400 bar				2									
20 bar				3									
100 bar				4									
<b>Measuring sensor</b>													
Diaphragm	Fill fluid												
Hastelloy C	Silicone oil				A								
	Carbon fluoride				B								
316 Ti stainless steel (1.4435)	Silicone oil				E								
(not 2010TA)	Carbon fluoride				F								
Tantalum	Silicone oil				J								
	Carbon fluoride				K								
Monel	Silicone oil				N								
	Carbon fluoride				P								
Gold plated	Silicone oil				T								
	Carbon fluoride				U								
<b>Process flange, HP and LP sides identical</b>													
316 Ti stainless steel (1.4571)	} Nominal pressure corresponding to measuring range pabs-sensor				J								
Hastelloy C					L								
Monel					M								
<b>Process Connection</b>		<b>Position of the thread holes for the drain / vent valves</b>											
		(scope of delivery: plugs only)											
7/16 UNF and 1/4-18 NPT	upright				A								
female thread	side				B								
acc. to DIN 19213	upright				C								
(M10/M12 and 1/4-18 NPT)	side				D								
<b>Bolts</b>		<b>Flange O-rings</b>											
Stainless Steel	Viton					6							
	Perbunan					7							
	PTFE					8							
	EPDM for NACE application					9							

Continued on next page.

# 2010TC for Differential Pressure, Pressure and Temperature (Mass Flow)

10/15-4.12 EN

## Model ordering number

Continued from preceding page.

			Catalog No.	Code			
Type	Material	Electrical connection					
Barrel - Type, ID Plate Plastic	Aluminium	1/2 NPT One M20 x 1.5 cable gland Plug Han 8U	D E F				
Barrel - Type, ID Plate Plastic	Stainless Steel	1/2 NPT One M20 x 1.5 cable gland	J K				
DIN - Type, ID Plate Plastic	Aluminium	1/2 NPT One M20 x 1.5 cable gland Plug Han 8U	L M N				
<b>Function</b>							
Customer-specific adjustment				5C1			
Conformity < 0.05 %				5C9			
<b>Amplifier housing accessories</b>							
Local keys				5C2			
LCD indicator				5C4			
LCD indicator, back lit				5C5			
Transient Suppression				5C6			
<b>Explosion Protection</b>							
EEx d IIC T6				5A1			
FM / CSA Explosion Proof / Intrinsically Safe				5A2			
EEx ia IIC T6				5A3			
Intrinsically Safe FM / CSA				5A4			
Zone 0				5A7			
<b>Mounting Bracket</b>							
Wall and pipe mounting, carbon steel				141			
Wall and pipe mounting, stainless steel				143			
<b>Vent / drain plug</b>							
Stainless Steel				395			
Hastelloy				396			
<b>Flange Adapter (material: oval flange / screws, (material: oval flange / bolts)</b>							
Oval flange 1/2-14 NPT(stainless steel / carbon steel)				376			
Oval flange 1/2-14 NPT(stainless steel / stainless steel)				377			
<b>Tag-No.</b>							
Stainless Steel Tag Plate				5C8			
<b>Operating manual</b>							
German				Z2D			
English				Z2E			

Continued on next page.

# 2010TC for Differential Pressure, Pressure and Temperature (Mass Flow)

10/15-4.12 EN

<b>Model ordering number</b>
------------------------------

Continued from preceding page.

	Catalog No.	Code		
<b>Certificates</b>				
Factory Certificate „EN 10 204“ of the instrument design		530		
Acceptance Test Certificate B „EN 10 204“ of the conformity, hysteresis		531		
Acceptance Test Certificate B „EN 10 204“ of the pressure testing		532		
Factory Certificate „EN 10 204“ of process wetted parts		533		
Acceptance Test Certificate B „10 204“ of the Cleanliness Stage acc. to DIN 25410		534		
Acceptance Test Certificate B „EN 10 204“ Helium leakage test of the sensor module		535		
Acceptance Test Certificate B „EN 10 204“ of the pressure-bearing and process wetted parts with analysis certificates as material verification (minor parts with Factory Certificate acc. to EN 10 204)		536		
Factory Certificate „EN 10 204“ of the pressure-bearing and process wetted parts		537		
Measuring mechanism leak-tested with helium		150		

**Scope of Delivery**

- 1 Instructions
- 1 Instrument socket with plug connector
- 2 Plugs

**Supplied against special order:**

- Remote Seal, Power supply e.g. TZN 128 (Data Sheet 18-8.39 EN)
- Spare Parts Transmitter 2010TD / 2010TA
- RTD (Data Sheets 10-3.22 EN up to 10-3.24 EN)

## Dimensional drawings

### 10 Construction

#### Transmitter with barrel-type amplifier housing

Errors and omissions excepted. Dimensions are in inches (mm).

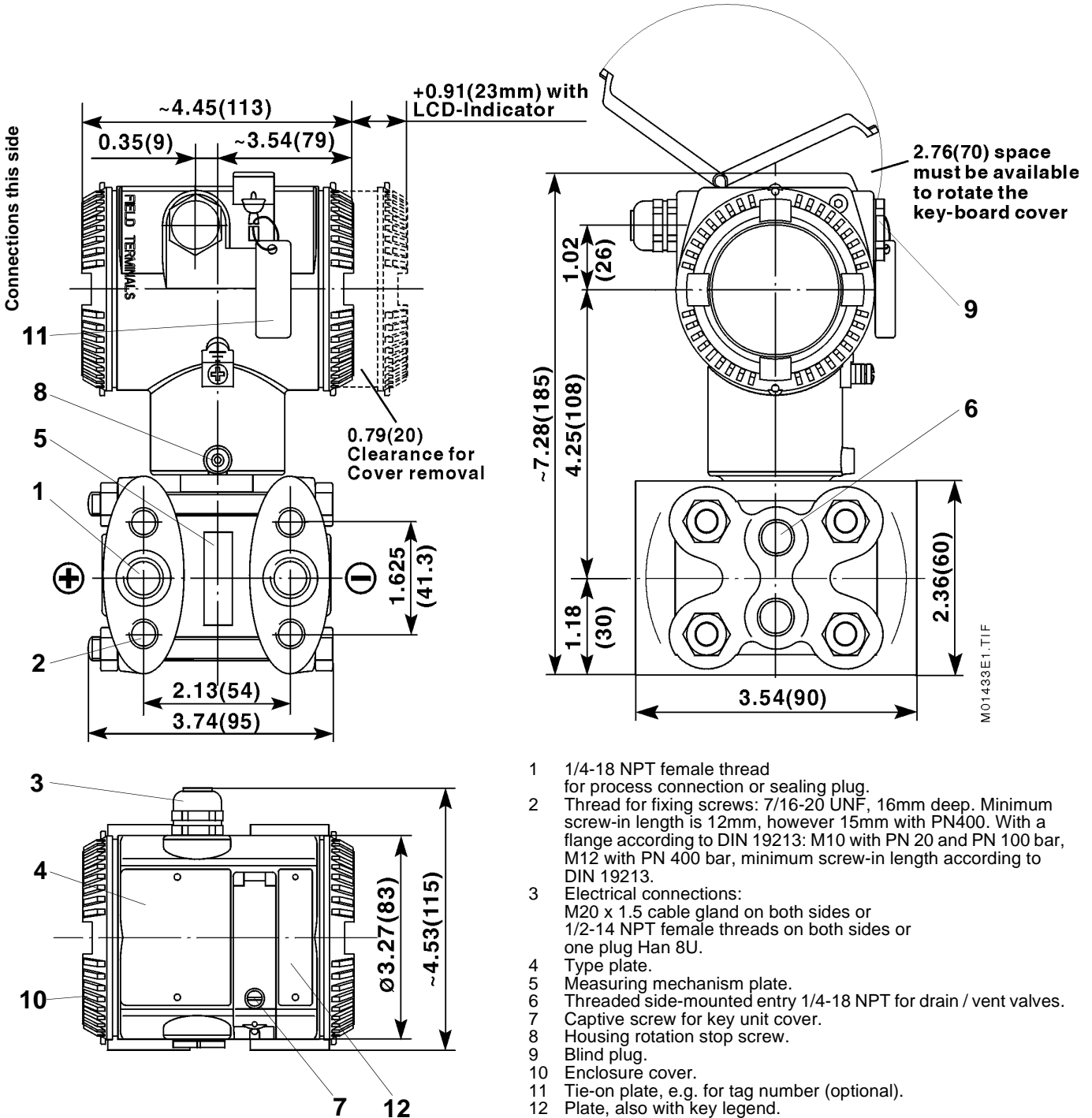

## Dimensional drawings

### Transmitter with DIN-type amplifier housing

Errors and omissions excepted. Dimensions are in inches (mm).

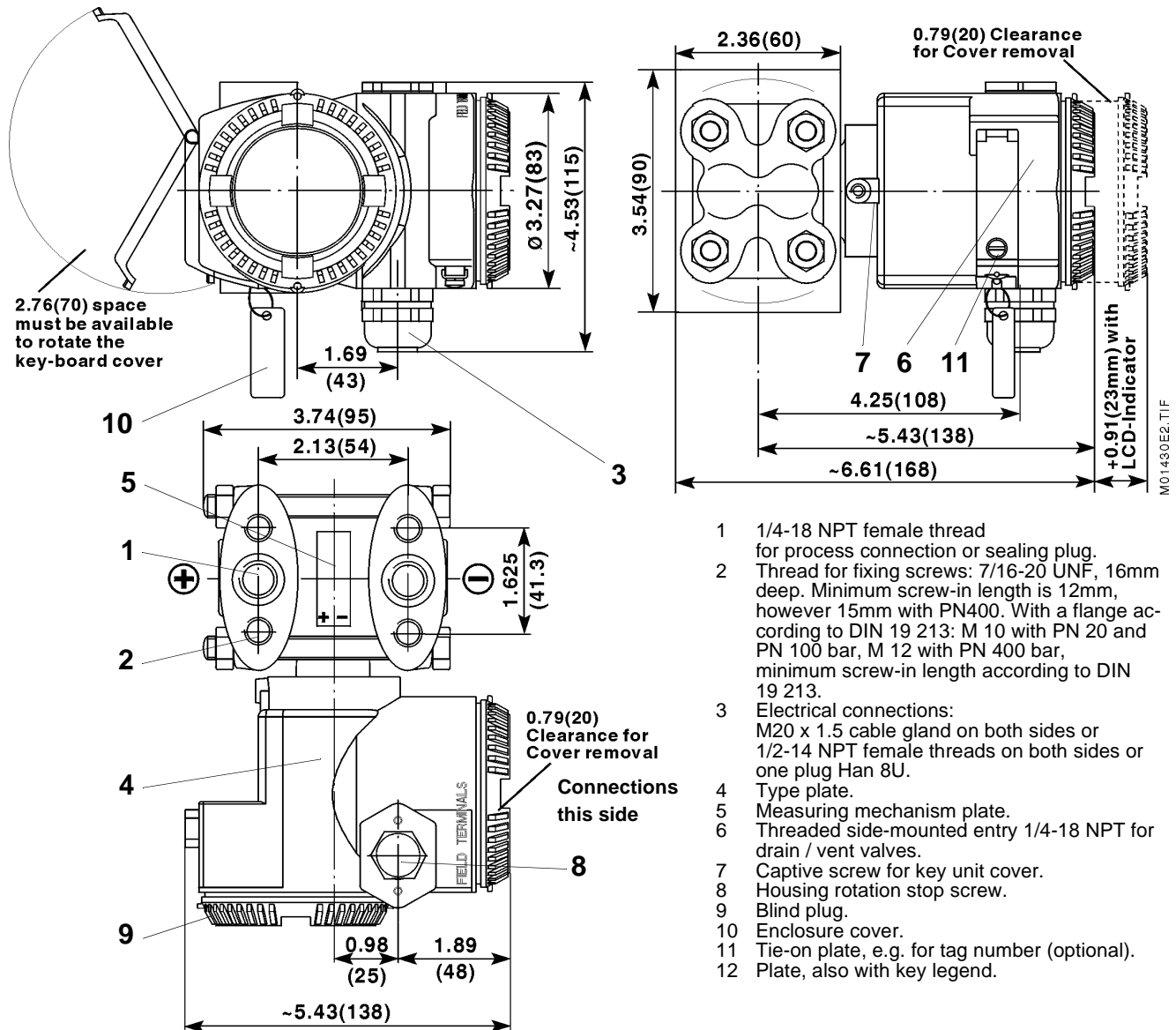



---

**ABB Automation Products GmbH**

Schillerstraße 72  
D-32425 Minden  
Tel. (05 71) 8 30-0  
Fax (05 71) 830-18 46  
<http://www.abb.de/automation>

Subject to technical changes.  
Printed in the Fed. Rep. of Germany  
10/15-4.12 EN 08.2000